

# IMPORTANT, SAVE FOR FUTURE REFERENCE: READ CAREFULLY

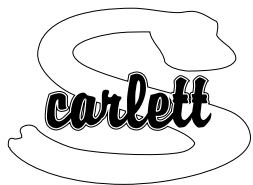

## Instructions for assembling the changing table

### 2470 Scarlett BUNO - ECO

The counter is made of beech wood without surface treatment (ECO),  
the shelves are made of HDF - the changing mat is made of MDF  
covered with polyurethane and coated with PVC

**Zdzislaw Krajewski - Scarlett**  
Velkoobchod s dětským zbožím  
Drahenská ul. 500,  
417 31 Novosedlice u Teplic  
tel./fax: +420 417 535 770  
www.scarlett.cz  
e-mail: info@scarlett.cz  
IČO: 62744763

#### Parts List

- 1 - changing area (1 pc)
- 2 - support rails (2 pcs.)
- 3 - foreheads (2 pcs.)
- 4 - lower hips (2 pcs.)
- 5 - upper hips (2 pcs.)
- 6 - shelves (2 pcs.)
- 7 - slats for the central shelf (2x)
- 8 - screw (4 pcs.)
- 9 - large screw (20 pcs.)
- 10 - shelf carrier (8 pcs.)
- 11 - long screw (4 pcs.)
- 12 - wooden peg (4 pcs.)
- 13 - torque wrench (1 pc.)

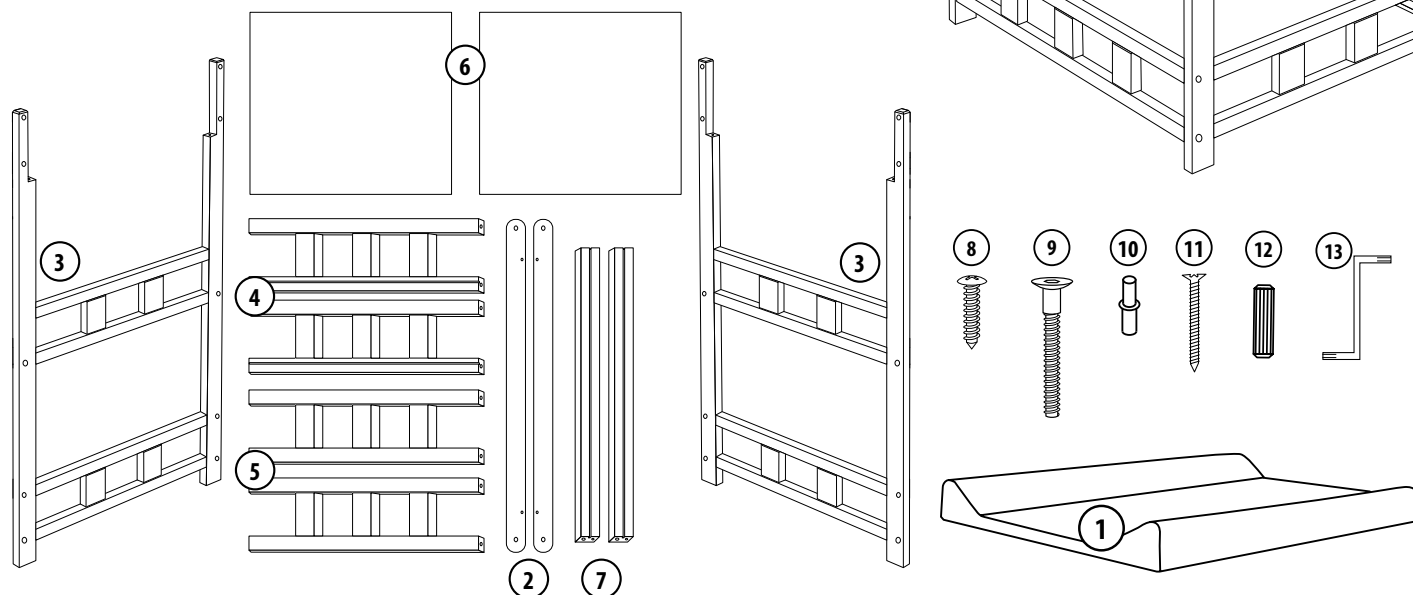
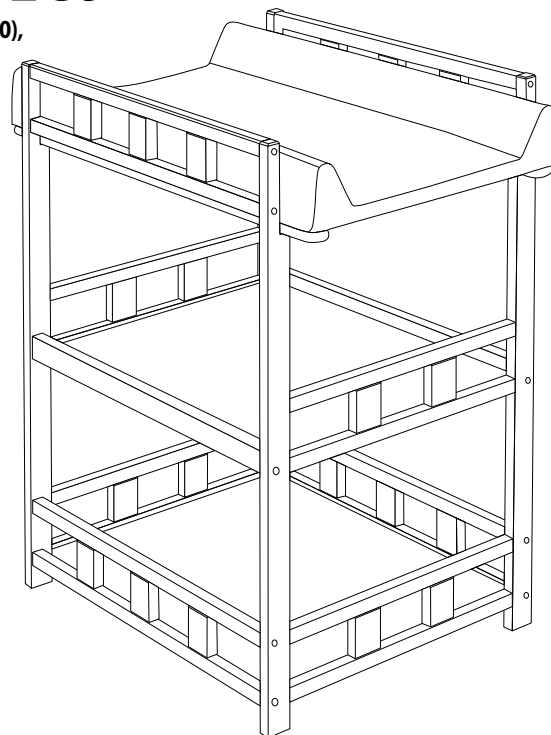

#### ASSEMBLY PROCEDURE

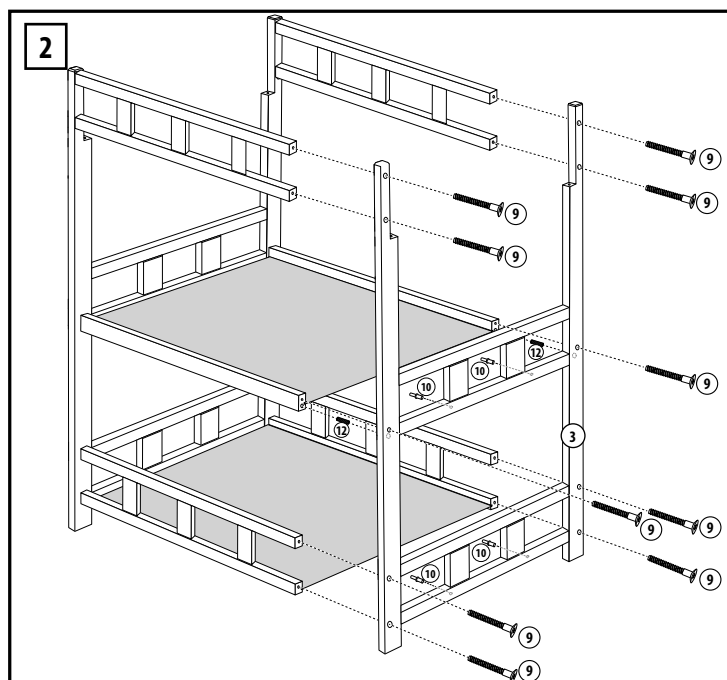
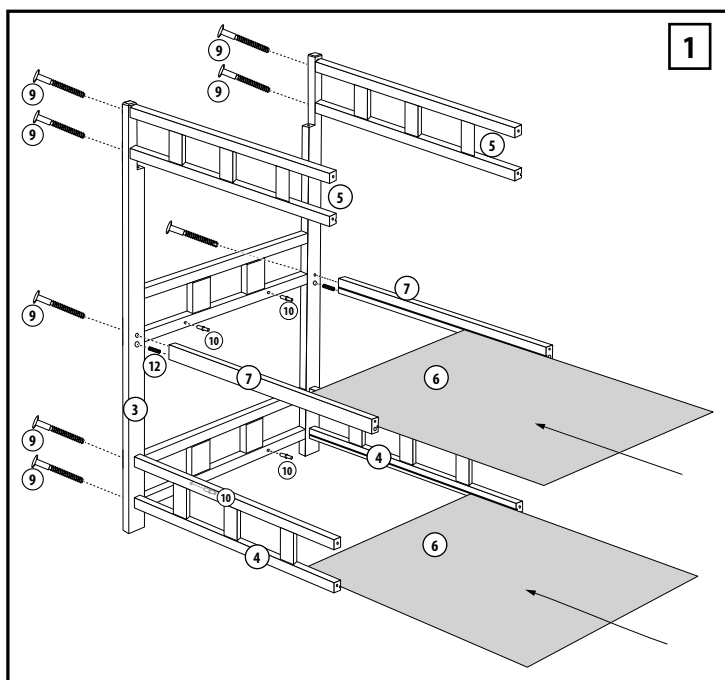

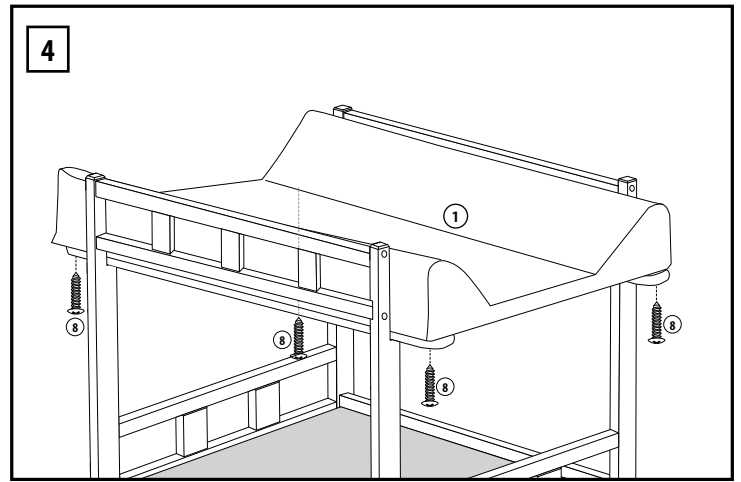
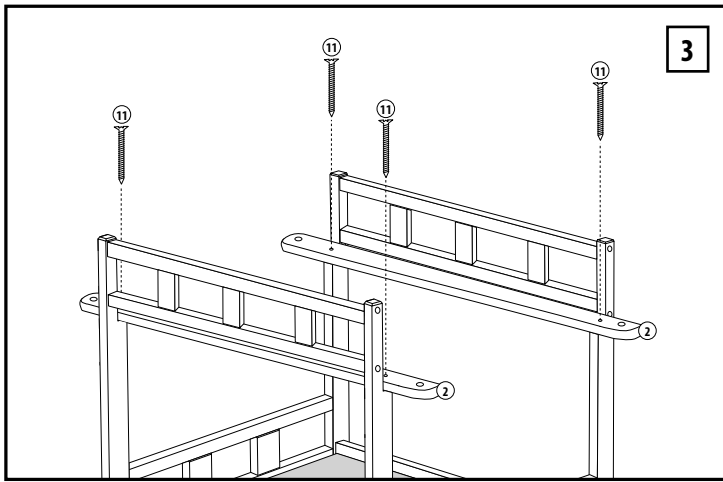

## INSTRUCTIONS FOR USING THE CHANGING PAD WITH A SOLID TOP

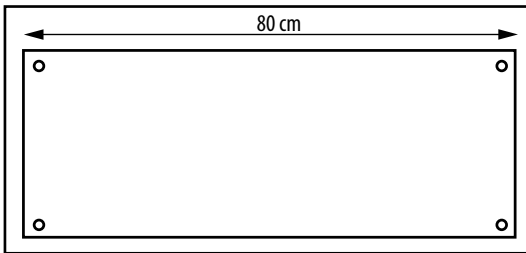

The changing mat for the crib is used to change the baby. The size of the changing pad is 80 x 50 cm.

Mounting the mat on the changing table: holes are pre-drilled in the lower part of the mat (they are covered with foil). The pre-drilled holes are located 2 cm from the edges (you can find them by pressing the foil with the tip of your finger).

**Composition:** interior - solid MDF board, filling - polyurethane, surface - PVC foil printed with food-grade paint. PVC and surface treatment comply with Decree of the Ministry of Health of the Czech Republic No. 8/2001 Coll., imposed on products for children under 3 years of age.

**WARNING:** Use only a cloth moistened with clean water to clean the pad surface. The use of other cleaning agents and chemicals may cause damage to the cover film (do not use any baby wet wipes or milk of any brand for cleaning).

Damage caused by the use of prohibited means and mechanical damage (impact, fall) cannot be claimed.

## SAFETY

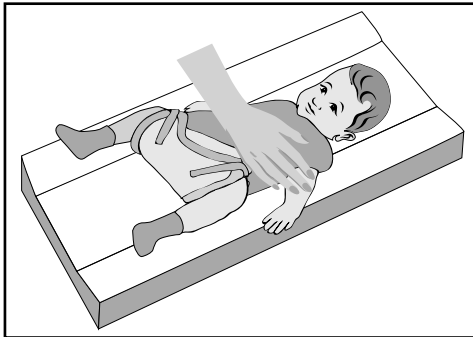

- Do not leave the child unattended on the changing table for even a moment!
- Place the counter at a sufficient distance from heat sources (radiators, stoves, etc.), sunlight and other heat sources, as well as from electrical sockets, extension cables and other electrical wires and equipment.
- Make sure the changing table is on a level surface and the wheels are locked.
- Assembly of the changing table may only be carried out by an adult; do not use the counter if it is not fully assembled or if any parts are missing.
- The use of accessories that are not approved by the manufacturer can be dangerous.

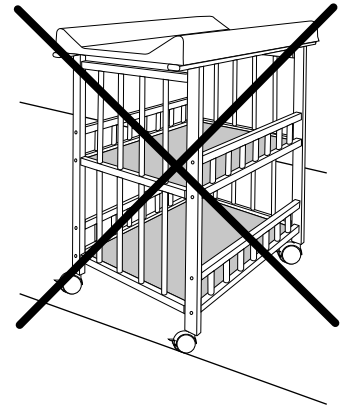

## IMPORTANT WARNING

- Read this manual and keep it for future reference. If you do not follow it, you may endanger the safety of the child.
- Take care to properly remove the packaging material (foils, plastic, cartons, etc.) out of reach of the child.
- Keep the counter clean only with a slightly moistened cotton cloth without any chemicals.

## RECOMMENDATION

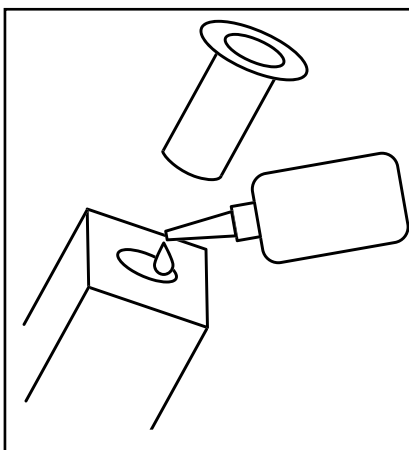

**The wheels are not part of the counter, their assembly and use of the counter with wheels is at your own risk.**

The legs of the counter are pre-drilled for possible installation of wheels. The wheels are only used to move around the room on a horizontal surface.

**Attention!**

When driving over thresholds or other irregularities, the legs of the counter can be damaged (broken).